



LED Surgical Headlight Battery Charger

Power Pack Charging Base Station
REF 80100-001

Power Pack Single Battery Charger
REF 80101-001

Instructions For Use

Introduction

This Instructions For Use manual is the most comprehensive source of information for the safe and effective use of your product. This manual may be used by in-service trainers, physicians, nurses, surgical technologists, biomedical equipment technicians, and central supply processing technicians. Keep and consult this reference manual during the life of the product.

The following conventions are used in this manual:

- A **WARNING** highlights a safety-related issue. Always comply with this information to prevent patient and/or healthcare staff injury.
- A **CAUTION** highlights a product reliability issue. Always comply with this information to prevent product damage.
- A **NOTE** supplements and/or clarifies procedural information.

If additional information, especially safety information, or in-service training is required, contact sales representative or Enova Customer Care Team at support@goenova.com

Trademarks not the property of Enova are the property of their respective owners.

Indications for Use

The LED Surgical Headlight Single Battery Charger is intended to charge one power pack at a time. The LED Surgical Headlight Power Pack Charging Base Station is intended to charge up to two power packs simultaneously.

Contraindications

Not known.

Limitations of Use

Not known.

User / Patient Safety



WARNING:

- Before using any component, or any component compatible with this equipment, read and understand the instructions. Pay particular attention to WARNING information. Become familiar with the components prior to use.

- Only trained and experienced healthcare professionals should use this equipment.
- Upon initial receipt and before each use, inspect each component for damage. Do not use any equipment if damage is apparent or the inspection criteria are not met. See the [Prior To Use] section for inspection criteria.
- Do not use the equipment in areas in which flammable anesthetics or flammable agents are mixed with air, oxygen or nitrous oxide.
- Do not stack or place equipment adjacent to the product. If such a configuration is necessary, observe the configuration to ensure that electromagnetic interference does not degrade performance.
- Persons allergic to TPE (Thermoplastic elastomer) or PC (Polycarbonate) plastics should not use this device.



- Do not use the product in a magnetic resonance imaging (MRI) environment. Using the product in an MRI environment could affect the function of the system.

Note: The expected service life of the LED Surgical Headlight Battery Charger is one (1) year.

For Use With



WARNING:

Always use the LED Surgical Headlight Battery Charger to charge power packs only, unless otherwise specified. Use of other power pack, power cords, or other components may result in malfunction or damages.

Accessories

This section describes components that may be ordered to replace original equipment that is damaged, worn, or must be replaced. This section may also contain optional components used with the equipment.



WARNING:

- Use only Enova-approved components and accessories, unless otherwise specified. Failure to comply may result in fire, electric shock, or injury.
- Using other electric components and accessories may result in increased electromagnetic emissions or decreased electromagnetic immunity of the system.
- Do not modify any component or accessory, including the ground of the battery charger power cord.

The following Enova-approved accessories are sold separately:

| DESCRIPTION | REF |
|--------------------|-----------|
| PP4+ Power Pack | 80205-001 |
| PP4 Power Pack | 80201-001 |
| NA C-13 Power Cord | 80150-002 |

Note: For a complete list of accessories, contact sales representative or Enova Customer Care Team at support@goenova.com

Features

REF 80100-001 Charging Base Station

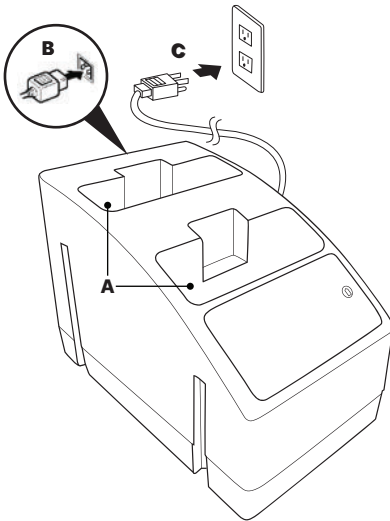

A. Base Station Modules:

Each module provides a pocket into which a power pack can be placed.

B. Power Cord Receptacle:

Connect the provided NA C-13 power cord to the power cord receptacle on the reverse of the base station before connecting to facility power. Always use the appropriate NA C-13 power cord. See the [Accessories] section.

C. Power Connection:

To connect or disconnect the base station to/from facility power, insert or remove the power cord connector to/from the power cord receptacle (appliance inlet).

REF 80101-001 Single Battery Charger

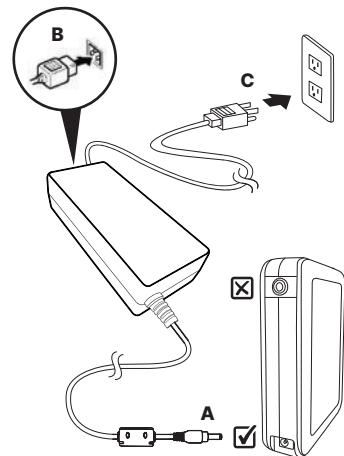

A. Single Battery Charger Tip:

Plug the single battery charger tip to the charging port on the bottom of the power pack to charge the power pack.

B. Power Cord Receptacle:

Connect the provided NA C-13 power cord to the power cord receptacle on a side of the single charger before connecting to facility power. Always use the appropriate NA C-13 power cord. See the [Accessories] section.

C. Power Connection:

To connect or disconnect the single battery charger to/from facility power, insert or remove the power cord connector to/from the power cord receptacle (appliance inlet).

Instructions



WARNING:

- Always perform the recommended inspection as indicated in the [Prior To Use] section.
- This equipment is suitable to use in a professional healthcare facility environment.
- Always operate the equipment within the specified environment condition values. See the [Specifications] section.
- Always operate the equipment at the specified voltage. See the [Specifications] section.
- To avoid the risk of electric shock, always connect this equipment to a hospital-grade, facility power receptacle with protective ground.
- Always position the equipment so that the power cord may be easily disconnected as required.
- Always place the power cord away from personnel traffic areas to eliminate a trip hazard and cord damage.
- Do not touch the power pack receptacle terminals of the battery charger module with a metal object.

To Set Up the Battery Charger (REF 80100-001/80101-001)

1. Position the battery charger so that the power cord may be easily connected and disconnected as required.
2. Install the non-metallic plug of the power cord into the power cord receptacle on the battery charger.
3. Install the other end of the power cord into a power receptacle.

To Charge the Power Pack



WARNING:

- Always make sure the power packs are dry before charging.
- Do not charge a power pack that gives off an odor, generates heat, becomes discolored, or leaks.
- Do not touch the battery charger's voltage output terminals and the patient simultaneously. Failure to comply may result in electric shock.

POWER PACK CHARGING BASE STATION:

1. Insert a clean, dry power pack into a base station module. The power pack is properly seated in the module when the LED Battery Life Indicator lights come on and the battery beeps once.
2. Once charged, it is safe to store the power packs in the base station for up to three months. See Enova PP4+ Power Pack IFU or PP4 Power Pack IFU for long-term storage instructions.

POWER PACK SINGLE BATTERY CHARGER:

1. Plug a single battery charger in a clean, dry power pack. The power pack is properly connected when the LED Battery Life Indicator lights come on and the battery beeps once.
2. Once charged, it is safe to keep the power packs connected with single battery charger for up to three months. See Enova PP4+ Power Pack IFU or PP4 Power Pack IFU for long-term storage instructions.

Note: Charging item for the power packs is approximately 4-4.5 hours from full discharge. Actual charging time depends on the remaining battery in the power pack before charging.

To Turn Off the Battery Charger (REF 80100-001/80101-001)

CAUTIONS: To reduce the risk of damage to the power cord, always grasp and pull the (mains) connector and plug when disconnecting the power cord from the battery charger and facility power.

1. Remove power cord plug from the power receptacle.
2. Remove the power cord connector from the power cord receptacle(appliance inlet) on the battery charger.

Note: If the battery charger is disconnected from facility power, remove the power packs from the modules to prevent discharge.

Prior To Use



WARNING: • Only individuals trained and experienced in the maintenance of medical devices should inspect this equipment.

- Upon initial receipt and before each use, inspect each component for damage. Do not use any equipment if damage is apparent or the inspection criteria are not met.
- Do not disassemble or service this equipment, unless otherwise specified. Failure to comply may result in electric shock or fire.

Note: For service, contact sales representative or Enova Customer Care Team at support@goenova.com

| INTERVAL | INSPECTION CRITERIA | ACTION |
|-----------------|--|---|
| Before each use | Check equipment for damage, wear, or missing components. | If damage is apparent, replace the equipment. |
| | Check power cord for cuts or bent pins. | |
| | Check power cord receptacle or base station module for bent pins. | |
| | Check battery charger housing and power pack housing for cracks. A cracked power pack housing has the potential to leak electrolytes and cause chemical burns. | |

Note: If any component must be discarded, see the [Disposal / Recycle] section.

Cleaning



WARNING:

- Before cleaning the battery charger, always disconnect the battery charger from facility power to reduce the risk of electric shock.
- Before cleaning the power pack, always disconnect the power pack from the twist cable.
- Do not immerse any component in liquid, including the power pack.
- Do not sterilize any component, including the power pack.
- Do not use disinfectants with a pH level higher than 7.5 on the power pack. See the [Safety Data Sheet] of the disinfectant to verify the pH range. Failure to comply may cause the power pack housing material to crack and leak.

CAUTIONS:

- Do not use solvents, lubricants, or other chemicals, unless otherwise specified.
- Do not allow liquids or moisture into any electrical connections, including the power cord receptacle.
- Do not allow water to collect in the base station module or on top of the battery charger.
- Always dry the power pack before installation into the battery charger. Failure to comply may result in damage to the power pack and battery charger.

TO CLEAN THE BATTERY CHARGER:

- Disconnect the battery charger power cord from the power cord receptacle and facility power.
- Wipe the surfaces of the battery charger with a soft cloth dampened with 70% isopropyl alcohol or mild soap. After cleaning, wipe the area with a lint-free soft cloth moistened with water to remove any residue from cleaning products.
- See the [Storage and Handling] section.

Storage and Handling

CAUTION

- **Always** store the equipment within the specified environmental condition values throughout its useful life. See the [Specifications] section.
- To ensure the longevity, performance and safety of this equipment, use of the composite carrying case or water tight packaging is recommended when storing or transporting this equipment.

Disposal / Recycle



WARNING:

Always follow the current local recommendations and/or regulations governing environmental protection and the risks associated with recycling or disposing of the equipment at the end of its useful life.

Specifications









| Model | Power Pack Charging Base Station REF 80100-001 | Power Pack Single Battery Charger REF 80101-001 |
|--------------------------------------|--|--|
| Input | 100-240V, 50/60Hz, 1.5A | 100-240V, 50/60Hz, 1.5A |
| Output | 10VDC, 1.4A | 10VDC, 1.4A |
| Power Cord | NA C-13 Power Cord | NA C-13 Power Cord |
| Ground Type | Protective Earth | Protective Earth |
| Means of Isolation from Supply Mains | Disconnect the power cord connector from the power cord receptacle (appliance inlet) | Disconnect the power cord connector from the power cord receptacle (appliance inlet) |
| Dimensions (Excl. Power Cord) | W110xD165xH110 mm | W117xD52xH33 mm |
| Ingress Protection (IP) | IPX0 | IPX0 |
| Mass (Incl. Power Cord) | 1470g | 720g |
| Equipment Classification | Class I Medical Electrical (ME) Equipment | Class I Medical Electrical (ME) Equipment |
| Mode of Operation | Continuous | Continuous |







| Environmental Condition | Operation | Storage and Transportation |
|-------------------------|-----------|----------------------------|
| Temperature | | |
| Humidity | | |
| Atmospheric Pressure | | |

Symbol Definition

TO USE AN LED SURGICAL HEADLIGHT:

The symbols located on the equipment and/or labeling are defined in this section or in the [Symbol Definition Chart]. See [Symbol Definition Chart] supplied with the equipment.

| Symbol | Definition (Indication Color) |
|--|--|
|  | General Warning Sign (Yellow) BS EN ISO 7010 Ref. W001 |
|  | Refer to Instruction Manual/Booklet (Blue) BS EN ISO 7010 Ref. M002 |
|  | Battery Charger |
|  | ETL Certified |
|  | Catalog Number BS EN ISO 15223-1 Ref 5.1.6 |
|  | Alternating Current (AC) |
|  | Direct Current (DC) |
|  | Protective Earth |

| Symbol | Definition (Indication Color) |
|---|--|
|  | Temperature Limitation BS EN ISO 15223-1 Ref. 5.3.7 |
|  | Humidity Limitation BS EN ISO 15223-1 Ref 5.3.8 |
|  | Atmospheric Pressure Limitation BS EN ISO 15223-1 Ref 5.3.9 |
|  | MRI Unsafe (Red) |
|  | Non-ionizing |
|  | Distributor BS EN ISO 15223-1 Ref. 5.1.9 |
|  | Manufacturer BS EN ISO 15223-1 Ref 5.1.1 |

Power Pack Charging Status

| Battery Charge | Light Bars |
|----------------|-----------------------------|
| 10-19% | 1 Green Light |
| 20-39% | 2 Green Light |
| 40-59% | 3 Green Light |
| 60-94% | 4 Green Light |
| 95-99% | 5 Green Light |
| 100% | 1 Green Light in the middle |

Troubleshooting



WARNING: Do not disassemble or service this equipment, unless otherwise specified.



Note: For service, contact sales representative or Enova Customer Care Team at support@goenova.com

| PROBLEM | CAUSE | ACTION |
|--|--|---|
| The power pack becomes unusually hot during use or while charging. | The power pack is damaged. | Replace the power pack. See the [For Use With] section. |
| | The battery charger is not functioning properly. | Return the battery charger to Enova. |

Guidance of Electromagnetic Immunity

The LED Surgical Headlight Battery Charger is intended for use in the electromagnetic environment specified below. The customer or user of the battery charger should assure that it is used in such an environment.

Note: The values provided in the table below follow IEC 60601-1-2:2014 requirements.

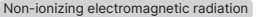
| IMMUNITY TEST | IEC 60601-1-2 TEST LEVEL | ELECTROMAGNETIC ENVIRONMENT GUIDANCE |
|--|--|---|
| Electrostatic discharge (ESD) IEC 61000-4-2 | ±8kV contact ±2kV, ±4kV, ±8kV, ±15kV air | Floor should be wood, concrete, or ceramic tile. If floors are covered with synthetic material, the relative humidity should be at least 30%. |
| Electrical fast transient/ burst IEC 61000-4-4 | ±2kV at 100kHz repetition frequency for power supply lines ±1kV at 100kHz repetition frequency for input/output lines | Main power source should be that of a typical commercial or hospital environment. |
| Surge IEC 61000-4-5 | ±0.5kV, ±1kV line(s) to line(s) at 0°, 90°, 180°, 270° ±0.5kV, ±1kV, ± 2kV line(s) to earth at 0°, 90°, 180°, 270° | Main power source should be that of a typical commercial or hospital environment. |
| Power frequency (50/60Hz) magnetic field IEC 61000-4-8 | 3 A/m, 30 A/m at 50Hz and 60Hz | Power frequency magnetic fields should be at levels characteristic of a typical location in a typical commercial or hospital environment. |
| Voltage dips, short Interruptions and voltage variations on power supply input lines IEC 61000-4-11 | <5% UT (>95% dip in UT) for 0.5 cycle 40% UT (60% dip in UT) for 5 cycles 0% UT (100% dip in UT) for 0.5 cycle at 0°, 45°, 90°, 135°, 180°, 225°, 270°, 315° 0% UT (>100% dip in UT) for 1 cycle at 0° 70% UT (30% dip in UT) for 25 & 30 cycles at 0° <5% UT (>95% dip in UT) for 5 seconds 0% UT (100% dip in UT) for 250/300 cycle | Main power source should be that of a typical commercial or hospital environment. |
| Conducted RF IEC 61000-4-6 | 3V 0.15MHz – 80MHz 6V in ISM bands between 0.15MHz and 80MHz 80% AM at 1kHz |  WARNING: Portable and mobile RF equipment should be used no closer than 30cm to any part of the battery charger, including cables. Otherwise, degradation of the performance of this equipment could result. Interference may occur in the vicinity of equipment marked with the following symbol:   |
| Radiated RF IEC 61000-4-3 | 3 V/m 80MHz to 2.7GHz, 80% AM at 1kHz 27 V/m 385 MHz, pulse modulation 18Hz Maximum power = 1.8W 28 V/m 450MHz, FM ±5kHz deviation, 1kHz sine Maximum power = 2W 9 V/m 710, 745, 780, 5240, 5500, 5785MHz, pulse modulation 217Hz Maximum power = 0.2W 28 V/m 810, 870, 930MHz, pulse modulation 18Hz Maximum power = 2W 28 V/m 1720, 1845, 1970, 2450MHz, pulse modulation 217Hz Maximum power = 2W | |

International Electrotechnical Commission (IEC)

IEC 60601-1:2005+AMD1:2012+AMD2:2020, Ed: 3.2, Medical electrical equipment - Part 1: General requirements for basic safety and essential performance
 IEC 60601-1-6:2010+AMD1:2013+AMD2:2020, Ed: 3.2, Medical electrical equipment - Part 1-6: General requirements for basic safety and essential performance
 IEC 62366-1:2015+AMD1:2020, Ed: 1.1, Medical devices - Part 1: Application of usability engineering to medical devices
 IEC 62133-2:2017+AMD1:2021, Ed:1.1, Secondary cells and batteries containing alkaline or other non-acid electrolytes - Safety requirements for portable sealed secondary lithium cells, and for batteries made from them, for use in portable applications - Part 2: Lithium systems

American National Standards Institute (ANSI)/Association for the Advancement of Medical Instrumentation (AAMI)

AAMI E560601-1:2005 & A1:2012 & A2:2021 Medical electrical equipment-Part 1: General requirements for basic safety and essential performance

Canadian Standards Association (CSA)

CAN/CSA C22.2 NO. 60601-1:14 + A2:22 (R2022) Medical electrical equipment - Part 1: General requirements for basic safety and essential performance
 CAN/CSA C22.2 NO. 60601-1-6:11 (R2021) Medical electrical equipment - Part 1-6: General requirements for basic safety and essential performance - Collateral standard:Usability

Enova Illumination

6305 Sandburg Road, STE 100
 Minneapolis, MN 55427 USA
 1-651-236-8857

